

API 6A GATE VALVES



Vitrol, Inc.

PROVEN PERFORMANCE • WORLD CLASS PRODUCTS

ViNtrol, Inc.

Quality Gate Valves for the Most Demanding Applications

ViNtrol, Inc. Gate Valve Product Line Offers:

- Design suitable for actuation and compatible with a wide range of actuators
- Valves for applications from 2000 to 15,000 psi WP.
- Positive Metal to Metal sealing (gate-to-seat and seat-to-body)
- Bi-directional sealing design
- Valves fitting a wide range of land and offshore applications.
- -50° F to 650° F Service
- Full bore through conduit construction.
- Components constructed of various alloys and coatings for severe service applications.
- Expanding and Slab design available
- API 6A Safety Shutdown Valves
- API Specification 6A
- API Specification 6D

ViNtrol, Inc. has become a leader in the valve industry as a result of ViNtrol's ability to anticipate and supply the market's requirements. Every valve must meet or exceed standards mandated by our customers and the stringent industry requirements.

ViNtrol gate valves have earned a reputation in all types of service applications. Our attention to total quality and excellence enables ViNtrol, Inc. to consistently deliver the world's finest gate valves to fill customer's needs throughout the world. ViNtrol offers a wide variety of gate valves, actuators, and other 6A products to provide our customers with all of their drilling and production needs.



Index of Brochure Content

| | |
|--|----------|
| Available Gate Styles | 2 |
| Trim Specifications Table | 3 |
| 2000 - 5000 PSI Gate Valves | 4 |
| 2000 - 5000 PSI Dimension Tables | 5 |
| 10,000 - 15,000 PSI Gate Valves | 6 |
| 10,000 - 15,000 PSI Dimension Table | 7 |
| Safety Shutdown Valves | 8 |



ViNtrol Headquarters is located in Oklahoma City, Oklahoma

Available Gate Styles



Expanding Gate

ViNtrol's expanding-style gates are used in 2 1/16 thru 7 1/16, 2000 to 5000 Gate Valves. This popular gate design is used in manual valves to produce a high seating force against both the upstream and downstream seats simultaneously as the handwheel is tightened. This force effects a tight mechanical seal which is unaffected by line pressure fluctuations or vibration. The expanding gate allows a positive mechanical seal across both seats, both upstream and downstream, with or without line pressure.

Expanding-Style Gate Valve Availability

| Working Pressure (psi) | | | |
|------------------------|------|------|------|
| Size (in.) | 2000 | 3000 | 5000 |
| 2-1/16 | NW | NW | NW |
| 2-9/16 | NW | NW | NW |
| 3-1/8 | NW | NW | NW |
| 4-1/16 | NW | NW | NW |
| 7-1/16 | NW | NW | NW |



Slab Gate

ViNtrol slab-style gates are one-piece, solid gates which consistently deliver outstanding sealing performance throughout a wide range of conditions, bore sizes, and working pressures, including corrosive and abrasive fluid environments. These valves meet or exceed the requirements of API Specifications 6A, 6A SSV. Sizes include 1 13/16 thru 7 1/16, 2000 to 15,000PSI

The slab-style gate design effects a metal-to-metal seal on the flow stream and its simple, straightforward design makes it easy to maintain both low and high-pressure sealing situations where contaminants could pose a sediment problem.

Slab-Style Gate Valve Availability

| Working Pressure (psi) | | | | | |
|------------------------|------|------|------|--------|--------|
| Size (in.) | 2000 | 3000 | 5000 | 10,000 | 15,000 |
| 1-13/16 | — | — | — | NS | NS |
| 2-1/16 | NS | NS | NS | NS | NS |
| 2-9/16 | NS | NS | NS | NS | NS |
| 3-1/8 | NS | NS | NS | — | — |
| 3-1/16 | — | — | — | NS | BRS |
| 4-1/16 | NS | NS | NS | NS | BRS |
| 5-1/8 | — | — | — | NS | BRS |
| 7-1/16 | NS | NS | NS | NS | BRS |

Trim Specifications

| Trim Code | Body | Bonnet | Bonnet Seal Ring | Stem | Gate & Segment | Seat |
|---|------------------------------------|------------------------------------|------------------|-----------------------|-----------------------|-----------------------|
| T-21 AA | ASTM A487-4C | ASTM A487-4C | C/S | LOW ALLOY NITRIDED | LOW ALLOY NITRIDED | LOW ALLOY NITRIDED |
| For essentially noncorrosive liquids or gases. Typical examples are crude and refined oils, natural or refined gases and processed hydrocarbons. Typical uses are well-heads, manifolds, flowlines and other similar installations requiring a through conduit valve. The temperature limitations are -20° to 250° F. General Service. | | | | | | |
| T-22 BB | ASTM A487-4C | ASTM A487-4C | S/S | 17-4 PH NITRIDED | 17-4 PH NITRIDED | 17-4 PH NITRIDED |
| For substantially the same service as T-21 but where the corrosion of 13 Chrome Stainless Steel internal parts are desirable. Also usable for mildly corrosive fluids and gases when limited corrosion of the internal body surfaces can be tolerated. The temperature limitations are -20° to 250° F. Recommended when partial pressure of CO ₂ is greater than 30. General Service. | | | | | | |
| T-23 CC | ASTM A217-CA15 | ASTM A217-CA15 | S/S | 17-4 PH NITRIDED | 17-4 PH NITRIDED | 17-4 PH NITRIDED |
| For any liquid or gaseous product for which the resistance of the 13 Chrome Stainless is adequate. Also used where the resistance of Stainless Steel is desirable from the standpoint of product purity. The temperature limitations are -20° to 250° F. Recommended when partial pressure of CO ₂ is greater than 30. General Service. | | | | | | |
| T-24 EE | ASTM A487-4C | ASTM A487-4C | S/S | 17-4 PH NITRIDED | 17-4 PH NITRIDED | 17-4 PH NITRIDED |
| Primarily for sour gas and oil where resistance to Hydrogen Sulfide embrittlement is required. Also suitable for other chemicals, products or hydrocarbons when H ₂ S is present. May be used when CO ₂ is present in smaller amount than H ₂ S. The temperature limitations are -20° to 250° F. Conforms to NACE MR-01-75 Specification | | | | | | |
| T-26 FF | ASTM A217-CA15 | ASTM A217-CA15 | S/S | 17-4 PH NITRIDED | 17-4 PH NITRIDED | 17-4 PH NITRIDED |
| Primarily for sour gas and oil when CO ₂ content exceeds the H ₂ S content. It is intended to provide resistance to the metal loss type of corrosion usually associated with CO ₂ plus resistance to Hydrogen Sulfide embrittlement. The temperature limitations are -20° to 250° F. Conforms to NACE MR-01-75 Specification | | | | | | |
| T-27 BB | ASTM A487-4C w/ Plastic Coating | ASTM A487-4C w/ Plastic Coating | S/S | 17-4 PH NITRIDED | 17-4 PH NITRIDED | 17-4 PH NITRIDED |
| Primarily for use in untreated or uninhabited brackish saline water typically associated with oilfield waterflood projects and/or disposal wells in which the internal plastic coating of the body surfaces provides resistance to salt water corrosion. The internal parts are resistant to Sulfide embrittlement and corrosion. The temperature limitations are -20° to 250° F. General Service | | | | | | |
| T-36 DD | ASTM A487-4C Impact Tested | ASTM A487-4C Impact Tested | C/S | LOW ALLOY NITRIDED | LOW ALLOY NITRIDED | LOW ALLOY NITRIDED |
| For essentially noncorrosive liquids or gases. Typical examples are crude and refined oils, natural or refined gases and processed hydrocarbons. Typical uses are wellheads, manifolds, flowlines and other similar installations requiring a through conduit valve. The temperature limitations are -50° to 250° F. Conforms to NACE MR-01-75 Specification | | | | | | |
| T-37 EE | ASTM A487-4C Impact Tested | ASTM A487-4C Impact Tested | S/S | 17-4 PH NITRIDED | 17-4 PH NITRIDED | 17-4 PH NITRIDED |
| Primarily for sour gas and oil where resistance to Hydrogen Sulfide embrittlement is required. Also suitable for other chemicals, products or hydrocarbons when H ₂ S is present. May be used when CO ₂ is present in smaller amount than H ₂ S. The temperature limitations are -50° to 250° F. Conforms to NACE MR-01-75 Specification | | | | | | |

- Charpy impact tests performed per requirements of API temperature rating.
- ViNtrol 10,000 and 15,000 psi gate valves are of forged construction 4130 material.
- ViNtrol gate valves are available in either T-36 or T-37 trim for immediate delivery.
- Corrosion Resistant Inconel 718 trim is available for NACE services above 0.5 psi partial pressure of H₂S

2000 - 5000 PSI Gate Valves

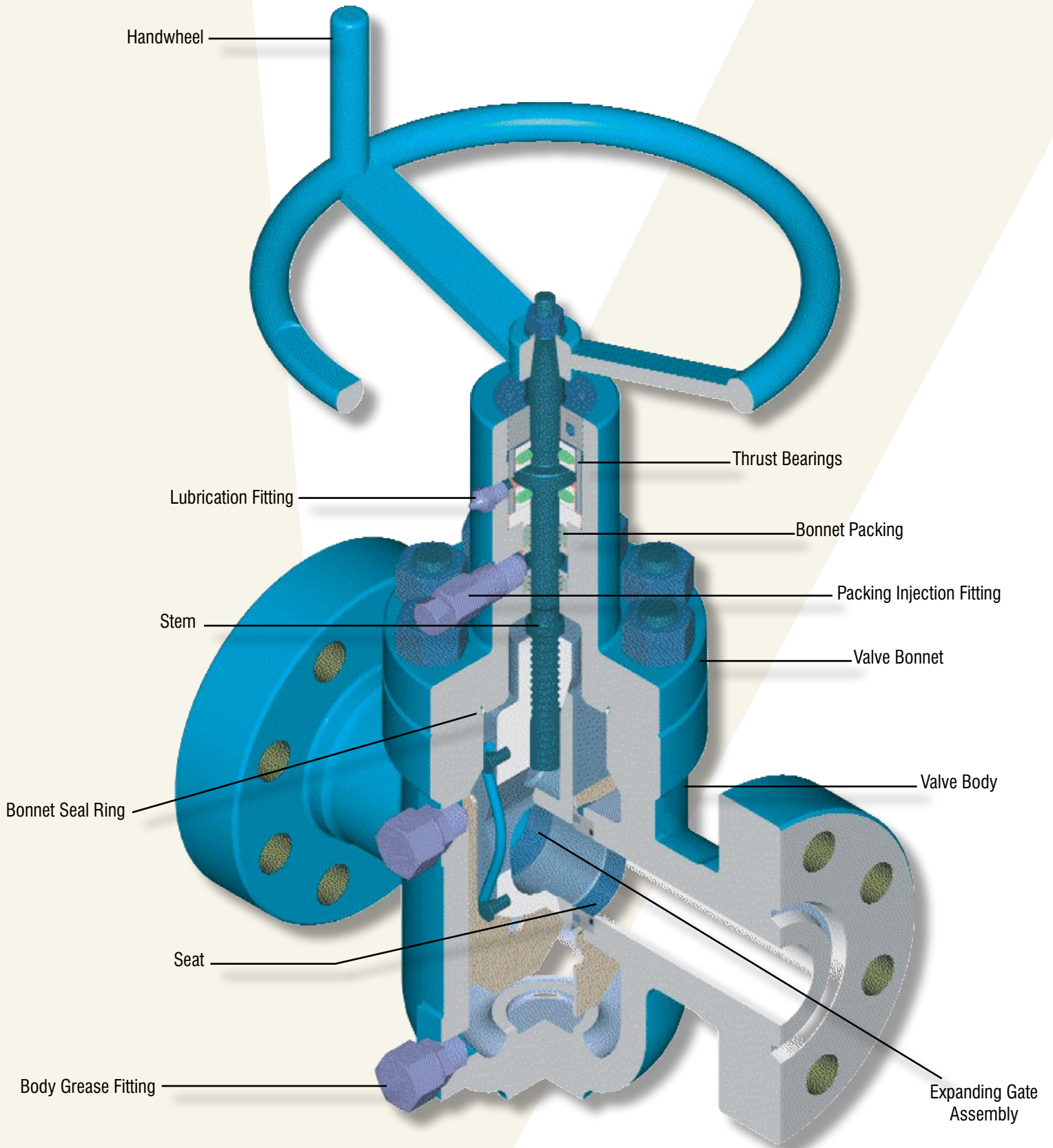

6A THREADED END VALVE DIMENSIONS

2000 PSI Working Pressure

| Size | Bore(A) | B | C | D | E | N | Wt. |
|--------|---------|-------|------|-------|-------|-------|-----|
| 2 1/16 | 2.06 | 9.63 | 5.19 | 14.81 | 11.00 | 13.00 | 93 |
| 2 1/16 | 52.4 | 235 | 131 | 376 | 280 | 13.00 | 42 |
| 2 9/16 | 2.56 | 10.25 | 6.25 | 15.50 | 13.00 | 15.75 | 119 |
| 2 9/16 | 65.1 | 260 | 158 | 394 | 330 | 15.75 | 54 |
| 3 1/8 | 3.12 | 11.44 | 7.75 | 17.63 | 13.00 | 20.50 | 190 |
| 3 1/8 | 79.4 | 290 | 196 | 448 | 330 | 20.50 | 86 |
| 4 1/16 | 4.06 | 13.38 | 9.25 | 20.44 | 16.00 | 24.50 | 313 |
| 4 1/16 | 103.2 | 340 | 235 | 519 | 406 | 24.50 | 142 |

3000 - 5000 PSI Working Pressure

| Size | Bore(A) | B | C | D | E | N | Wt. |
|--------|---------|-------|------|-------|-------|-------|-----|
| 2 1/16 | 2.06 | 9.63 | 5.75 | 14.81 | 13.00 | 13.00 | 128 |
| 2 1/16 | 52.4 | 245 | 145 | 376 | 330 | 13 | 58 |
| 2 9/16 | 2.56 | 10.25 | 6.50 | 15.50 | 16.00 | 15.75 | 154 |
| 2 9/16 | 65.1 | 260 | 165 | 394 | 406 | 15.75 | 70 |
| 3 1/8 | 3.12 | 11.63 | 8.00 | 17.63 | 16.00 | 20.50 | 247 |
| 3 1/8 | 79.4 | 295 | 202 | 448 | 406 | 20.50 | 112 |
| 4 1/16 | 4.06 | 14.38 | 9.56 | 20.44 | 20.00 | 24.50 | 417 |
| 4 1/16 | 103.2 | 365 | 243 | 519 | 508 | 24.50 | 196 |

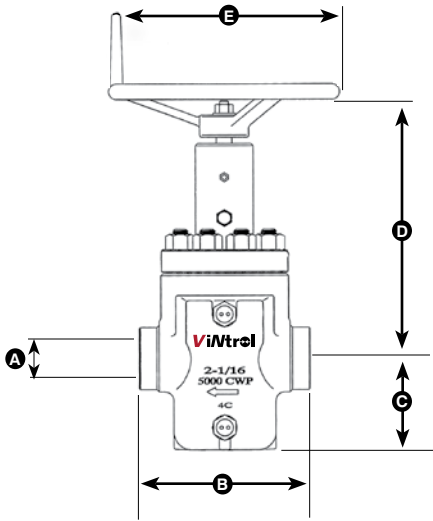

size in inches
 size in millimeters

N = Number of turns to open and close valve.

size in inches
 size in millimeters

N = Number of turns to open and close valve.

6A FLANGED END VALVE DIMENSIONS

2000 PSI Working Pressure

| Size | Bore(A) | B | C | D | E | N | Wt. |
|--------|---------|-------|-------|-------|-------|-------|------|
| 2 1/16 | 2.06 | 11.63 | 5.19 | 14.81 | 11.00 | 13.00 | 111 |
| 2 1/16 | 52.4 | 295 | 131 | 376 | 280 | 13.00 | 50 |
| 2 9/16 | 2.56 | 13.13 | 6.25 | 15.50 | 13.00 | 15.75 | 150 |
| 2 9/16 | 65.1 | 333 | 158 | 394 | 330 | 15.75 | 68 |
| 3 1/8 | 3.12 | 14.13 | 7.75 | 17.63 | 13.00 | 20.50 | 225 |
| 3 1/8 | 79.4 | 359 | 196 | 448 | 330 | 20.50 | 106 |
| 4 1/16 | 4.06 | 17.13 | 9.25 | 20.44 | 16.00 | 24.50 | 388 |
| 4 1/16 | 103.2 | 435 | 235 | 519 | 406 | 24.50 | 182 |
| 7 1/16 | 7.06 | 26.13 | 13.88 | 27.94 | 20.00 | 39.00 | 1050 |
| 7 1/16 | 179.4 | 664 | 353 | 710 | 508 | 39.00 | 486 |

3000 PSI Working Pressure

| Size | Bore(A) | B | C | D | E | N | Wt. |
|--------|---------|-------|-------|-------|-------|-------|------|
| 2 1/16 | 2.06 | 14.63 | 5.75 | 14.81 | 13.00 | 13.00 | 174 |
| 2 1/16 | 52.4 | 371 | 145 | 376 | 330 | 13.00 | 79 |
| 2 9/16 | 2.56 | 16.63 | 6.50 | 15.50 | 16.00 | 15.75 | 223 |
| 2 9/16 | 65.1 | 422 | 165 | 394 | 406 | 15.75 | 107 |
| 3 1/8 | 3.12 | 17.13 | 7.81 | 17.63 | 16.00 | 20.50 | 295 |
| 3 1/8 | 79.4 | 435 | 199 | 448 | 406 | 20.50 | 134 |
| 4 1/16 | 4.06 | 20.13 | 9.88 | 20.44 | 20.00 | 24.50 | 520 |
| 4 1/16 | 103.2 | 511 | 239 | 519 | 508 | 24.50 | 236 |
| 7 1/16 | 7.06 | 28.13 | 13.88 | 27.94 | 24.00 | 39.00 | 1182 |
| 7 1/16 | 179.4 | 715 | 353 | 710 | 609 | 39.00 | 536 |

5000 PSI Working Pressure

| Size | Bore(A) | B | C | D | E | N | Wt. |
|--------|---------|-------|-------|-------|-------|-------|------|
| 2 1/16 | 2.06 | 14.63 | 5.75 | 14.81 | 13.00 | 13.00 | 174 |
| 2 1/16 | 52.4 | 371 | 145 | 376 | 330 | 13.00 | 79 |
| 2 9/16 | 2.56 | 16.63 | 6.50 | 15.50 | 16.00 | 15.75 | 223 |
| 2 9/16 | 65.1 | 422 | 165 | 394 | 406 | 15.75 | 107 |
| 3 1/8 | 3.12 | 18.63 | 8.00 | 17.63 | 16.00 | 20.50 | 346 |
| 3 1/8 | 79.4 | 473 | 202 | 448 | 406 | 20.50 | 157 |
| 4 1/16 | 4.06 | 21.63 | 9.56 | 20.44 | 20.00 | 24.50 | 558 |
| 4 1/16 | 103.2 | 549 | 243 | 519 | 508 | 24.50 | 280 |
| 7 1/16 | 7.06 | 32.00 | 14.31 | 27.94 | 30.00 | 39.00 | 1418 |
| 7 1/16 | 179.4 | 813 | 363 | 710 | 760 | 39.00 | 610 |

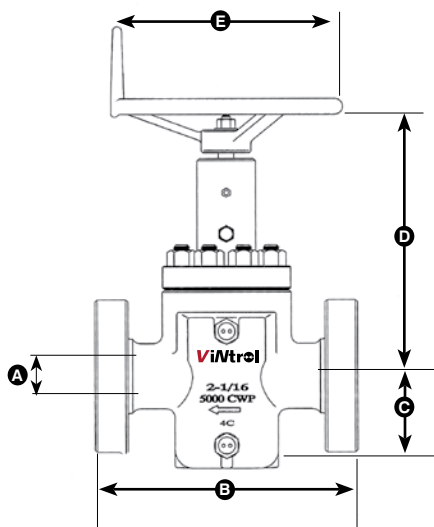

size in inches
 size in millimeters

N = Number of turns to open and close valve.

size in inches
 size in millimeters

N = Number of turns to open and close valve.

size in inches
 size in millimeters

N = Number of turns to open and close valve.

10,000 - 15,000 PSI Gate Valves

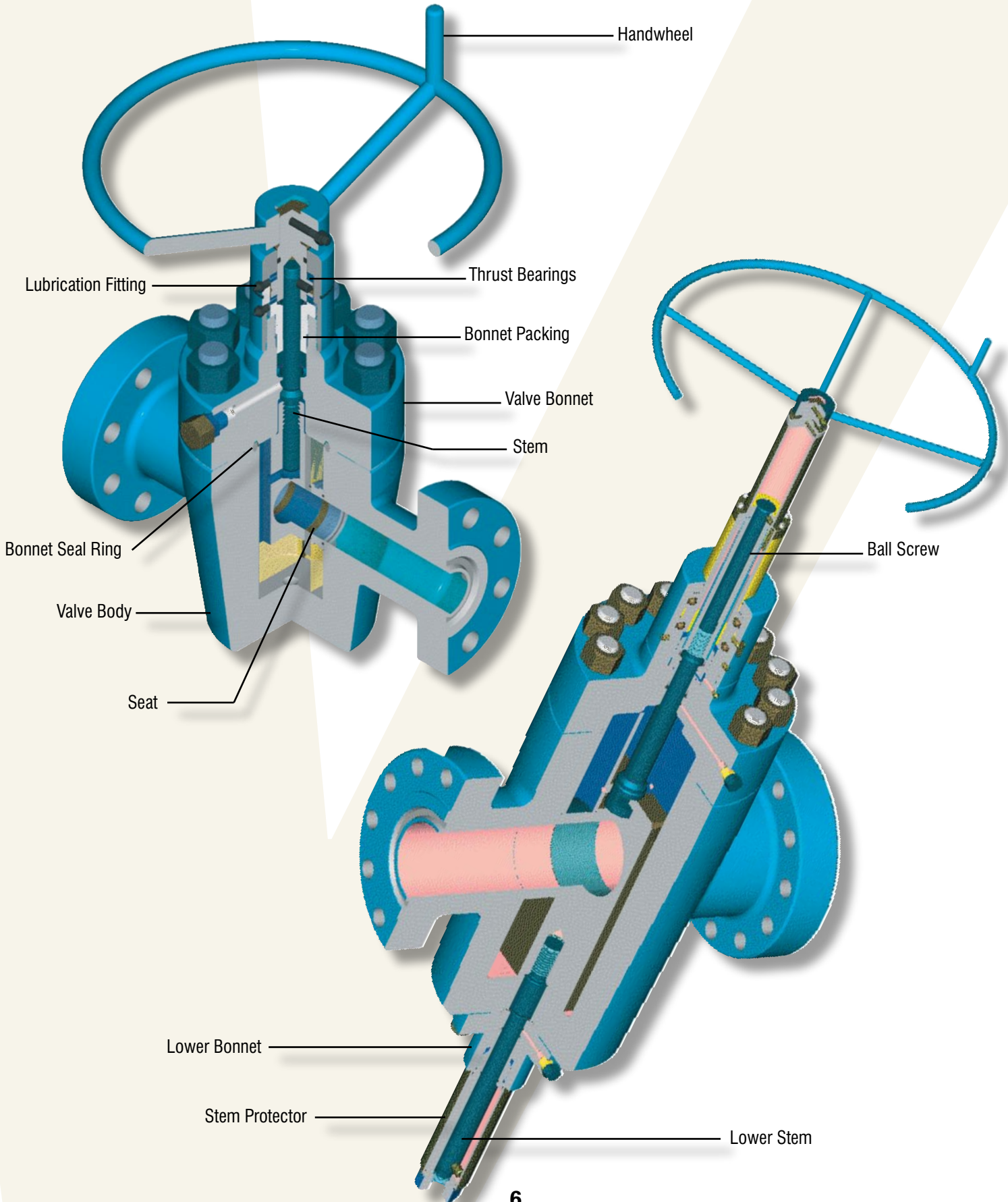

GATE VALVE DIMENSIONS

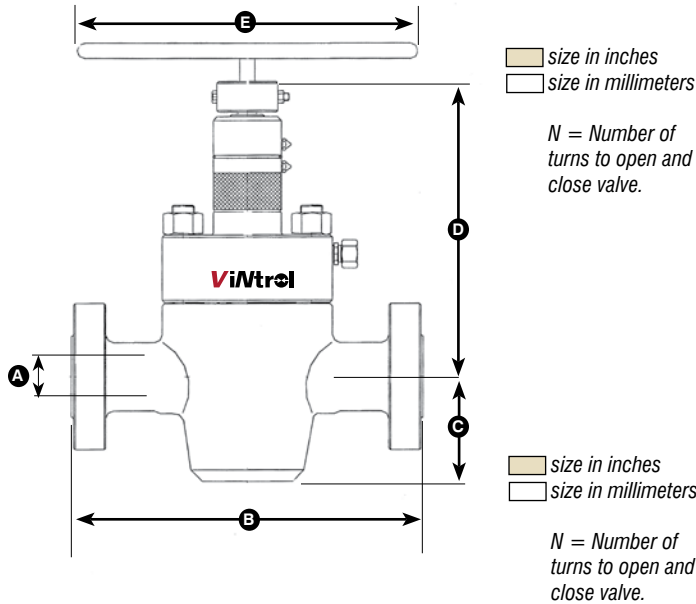

10,000 PSI Working Pressure

| Size | Bore(A) | B | C | D | E | N | Wt. |
|---------|---------|-------|-------|------|------|-------|-----|
| 1 13/16 | 1.81 | 18.25 | 5.78 | 15 | 13 | 12.25 | 270 |
| 1 13/16 | 46 | 464 | 147 | 381 | 330 | 12.25 | 124 |
| 2 1/16 | 2.06 | 20.5 | 5.78 | 15 | 16 | 12.25 | 305 |
| 2 1/16 | 52.4 | 521 | 147 | 381 | 406 | 12.25 | 139 |
| 2 9/16 | 2.56 | 22.25 | 6.81 | 15.8 | 20.5 | 15.00 | 390 |
| 2 9/16 | 65.1 | 565 | 173 | 402 | 520 | 15.00 | 177 |
| 3 1/16 | 3.06 | 24.38 | 7.8 | 16.7 | 23.6 | 17.88 | 540 |
| 3 1/16 | 79.4 | 619 | 198 | 425 | 600 | 17.88 | 245 |
| 4 1/16 | 4.06 | 26.38 | 10.12 | 19.8 | 23.6 | 23.25 | 930 |
| 4 1/16 | 103.2 | 670 | 257 | 502 | 600 | 23.25 | 425 |

15,000 PSI Working Pressure

| Size | Bore(A) | B | C | D | E | N | Wt. |
|---------|---------|-----|------|------|------|-------|-----|
| 1 13/16 | 1.81 | 18 | 6.18 | 15 | 13 | 12.25 | 320 |
| 1 13/16 | 46 | 457 | 157 | 381 | 330 | 12.25 | 146 |
| 2 1/16 | 2.06 | 19 | 6.18 | 15 | 16 | 12.25 | 360 |
| 2 1/16 | 52.4 | 482 | 157 | 381 | 406 | 12.25 | 165 |
| 2 9/16 | 2.56 | 21 | 7.5 | 17.4 | 20.5 | 15.50 | 590 |
| 2 9/16 | 65.1 | 533 | 190 | 442 | 520 | 15.50 | 269 |

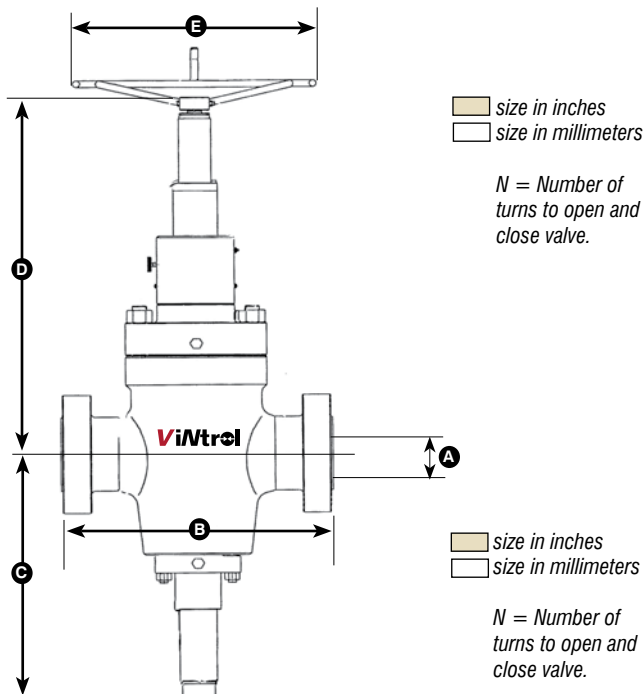

10,000 PSI Working Pressure (Balanced Stem)

| Size | Bore(A) | B | C | D | E | N | Wt. |
|----------|---------|-----|-------|-------|-----|------|------|
| 5 1/8 F | 5.12 | 29 | 28.79 | 42.38 | 26 | 24.0 | 1900 |
| 5-1/8 F | 130 | 737 | 731 | 1076 | 660 | 24.0 | 850 |
| 5 1/8 S | 5.12 | 16 | 28.79 | 42.38 | 26 | 24.0 | 1690 |
| 5-1/8 S | 130 | 406 | 731 | 1076 | 660 | 24.0 | 770 |
| 7 1/16 F | 7.06 | 35 | 37 | 49.55 | 30 | 33.0 | 3340 |
| 7-1/16 F | 179.4 | 889 | 940 | 1258 | 762 | 33.0 | 1530 |
| 7 1/16 S | 7.06 | 20 | 37 | 49.55 | 30 | 33.0 | 2970 |
| 7-1/16 S | 179.4 | 508 | 940 | 1258 | 762 | 33.0 | 1340 |

15,000 PSI Working Pressure (Balanced Stem)

| Size | Bore(A) | B | C | D | E | N | Wt. |
|----------|---------|-------|-------|-------|------|------|------|
| 3 1/16 F | 3.06 | 23.56 | 22.68 | 31.47 | 18.5 | 15.5 | 1200 |
| 3 1/16 F | 77.8 | 598 | 576 | 800 | 470 | 15.5 | 540 |
| 4 1/16 F | 4.06 | 29 | 26 | 37.5 | 26 | 19.2 | 1800 |
| 4 1/16 F | 103.2 | 737 | 660 | 952 | 660 | 19.2 | 820 |
| 5 1/8 F | 5.12 | 35 | 31.12 | 42.33 | 30 | 25.0 | 3100 |
| 5 1/8 F | 130 | 889 | 790 | 1075 | 762 | 25.0 | 1400 |
| 5 1/8 S | 5.12 | 20 | 31.12 | 42.33 | 30 | 25.0 | 2900 |
| 5 1/8 S | 130 | 508 | 790 | 1075 | 762 | 25.0 | 1300 |
| 7 1/16 F | 7.06 | 41 | 39 | 55.86 | 40 | 34.0 | 6800 |
| 7 1/16 F | 179.4 | 1041 | 990 | 1420 | 1016 | 34.0 | 3060 |
| 7 1/16 S | 7.06 | 26 | 39 | 55.86 | 40 | 34.0 | 6350 |
| 7 1/16 S | 179.4 | 660 | 990 | 1420 | 1016 | 34.0 | 2860 |

Safety Shutdown Valves



ViNtrol safety shutdown valves are designed to accommodate diaphragm, piston, and hydraulic actuator units by leading manufacturers. Body kits are also available in 2,000 to 15,000 PSI Pressure Ratings. ViNtrol will tailor special trim to customer specifications, depending on temperature and pressure ranges, corrosive or abrasive conditions and operational environment. ViNtrol gate valves with slab-style gates are compatible with major actuator manufacturers. For full information call Vintrol today.

Available with:

- **Diaphragm Actuators**
- **Piston Actuators**
- **Hydraulic Actuators**
- **Manual Over-ride**

ViNtrol Expanded Product Line

ViNtrol offers a wide variety of products for every oil field need. The following list gives an overview of the ViNtrol product line, for specific information on available products please contact your ViNtrol representative, or call the corporate offices toll free at 866-345-8298.

- **Flanged Floating Ball Valves**
- **Threaded End Floating Ball Valves**
- **Trunnion Ball Valves**
- **Adjustable and Positive Chokes**
- **Wellhead Components**

WARRANTY

ViNtrol products are guaranteed against defects of material workmanship for one (1) year from date of invoice, providing such products are used normally and within the service and pressure range to which they were manufactured. Claims for breach of the warranty shall be limited to replacement, free of charge, FOB Oklahoma City, OK, of any part or product that proves defective in material or workmanship, upon written notice of such defect given in thirty (30) days and return of such item to ViNtrol, Inc., Oklahoma City, OK. Costs of labor, freight, drayage, or other similar charges shall be at the customer's expense. This warranty is limited in extent to the warranty, if any, which the user receives from the manufacturers of any component parts. All other warranties or liabilities expressed or implied, oral or statutory, including any warranty of merchantability or fitness for a particular purpose are expressly denied. In no event shall ViNtrol, Inc., its agents or employees be liable for injury or damage to any person or property whatsoever or for any special, indirect, secondary, or consequential damage of any nature however arising.

ViNtrol reserves the right to change designs, materials or specifications without notice or without obligation to furnish or install such changes on products previously or subsequently sold.

ORDERS POLICY

All orders are subject to acceptance by ViNtrol, Inc. home office. Prices are subject to change without notice and any errors in published prices are subject to correction. No materials may be returned for credit without written authorization from ViNtrol. Credit will not be issued for materials after one year from the date of purchase. ViNtrol reserves the right to deduct reconditioning and handling charges when issuing credit for returned material. Products of special design, not conforming to our standard line, will not be accepted for credit.

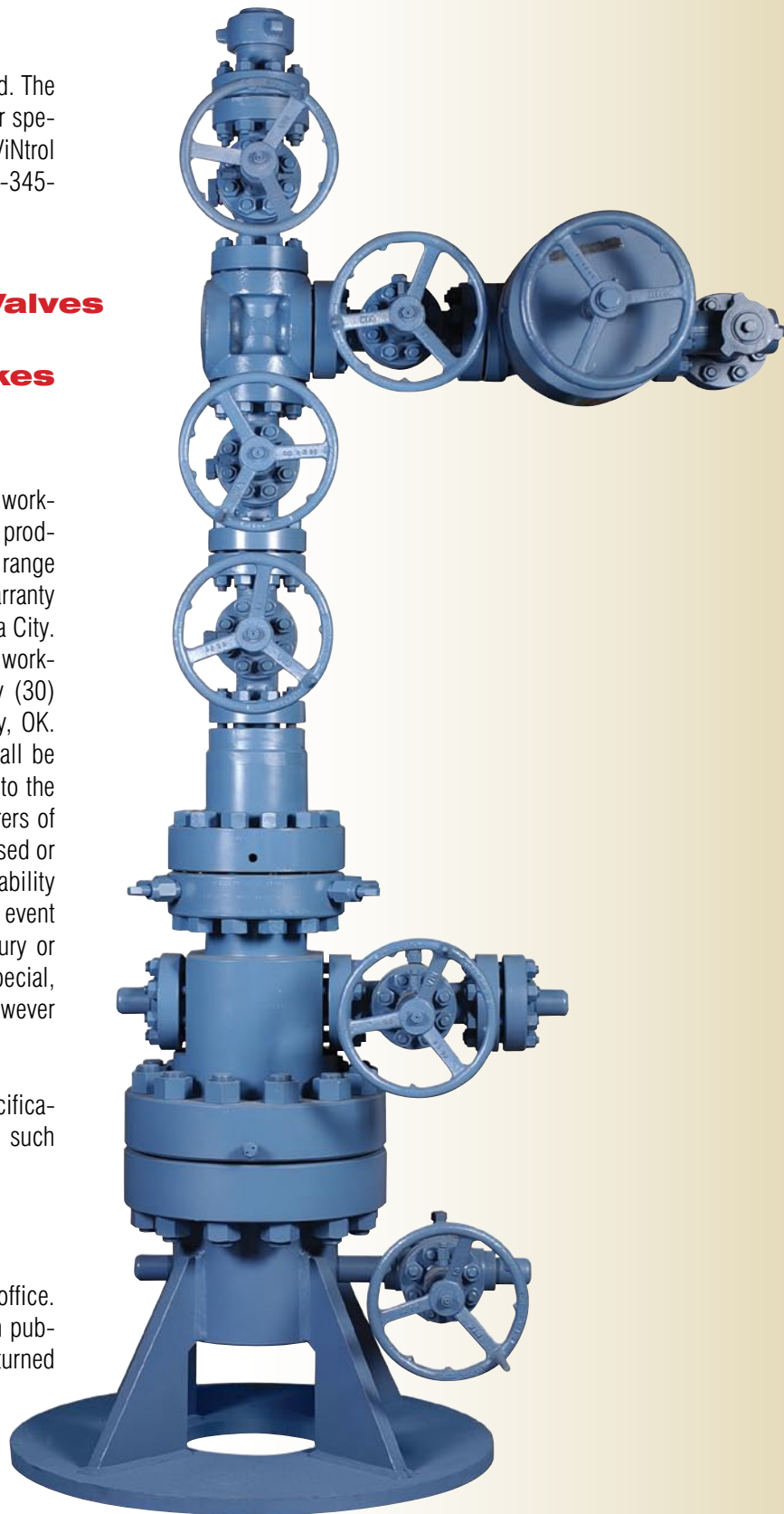

ViNtrol, Inc.

5325 SW 36th Street
Oklahoma City, OK 73179
Toll Free: 1-866-345-8298
Phone: 405-261-0770
Fax: 405-261-0774
Email: sales@vintrol.com
Website: www.vintrol.com